

18A
4017N

Hyundai Tucson, Md.2015-2018

EU-Spoilerschutzrohr 51 mm gekröpft mit Unterfahrschutzblech
EU-Spoiler protective tube 51 mm cranked with Underride guard plate
Tube de protection du spoiler vinklad CE 51 mm avec avant plaque



*Compatible with Automatic Cruise Control /Forward Collision Mitigation
Kompatibel mit Abstandsregeltempomat /Auffahrvermeidungs-oder warnsystem
compatible avec radar de régulation de distance/ freinage autonome d'urgence

ASSEMBLY INSTRUCTION

Montageanleitung • Instructions de montage

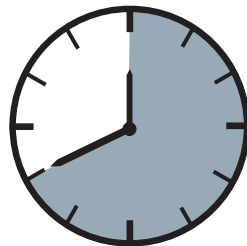

40 Minuten

article no.:

18A4017N (S) inox

18A5017N black steel

Revision 4: 27.09.2018



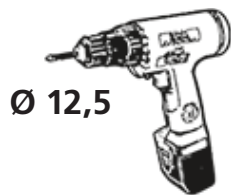
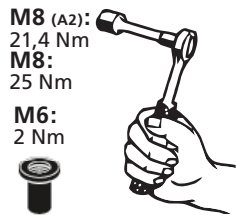

13

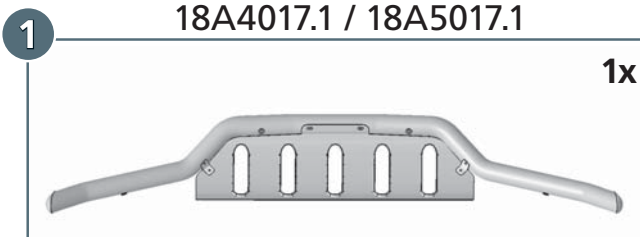
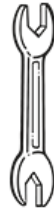

mounting kit: 18A9017N

	M6 x 25; DIN 7991 Zn	2x
	M8 x 20; DIN 933 Zn	4x
	M8 x 25; DIN 933 A2	4x
	Ø 8,4; DIN 9021 Zn	4x
	Ø 8,4; DIN 9021 A2	4x
	Ø 8; DIN 127 Zn	4x
	Ø 8; DIN 127 A2	4x
	Getowell M6	2x
	SW 13	2x

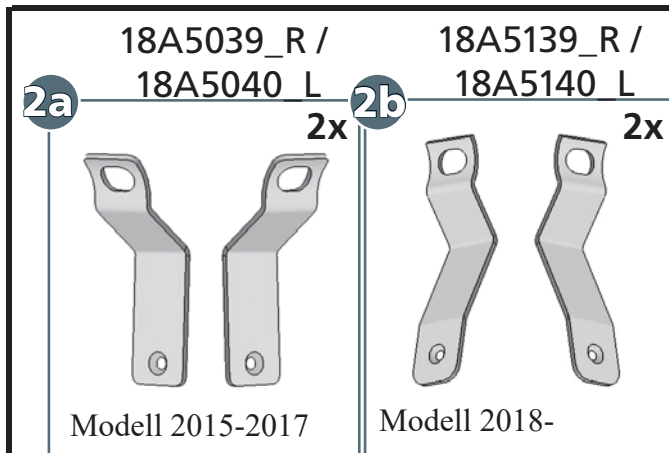

18A5037

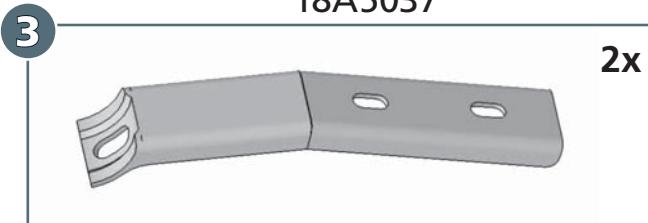

18A5020_R / 18A5021_L

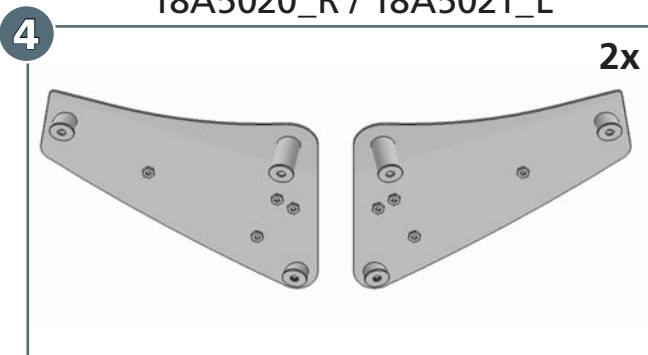

article no.:

18A4017N (S) inox

18A5017N black steel

Revision 4: 27.09.2018



