

**17L  
4313**

## **Nissan NP300 Navara D23, Md. 2015+2019**

EU-pedestrian protection bar 60 mm high with cross pipe 42 mm

EU-Personenschutzbügel 60 mm hoch mit Querrohr 42 mm

Protection avant, homologuée CEE, 60 mm, traverse 42 mm

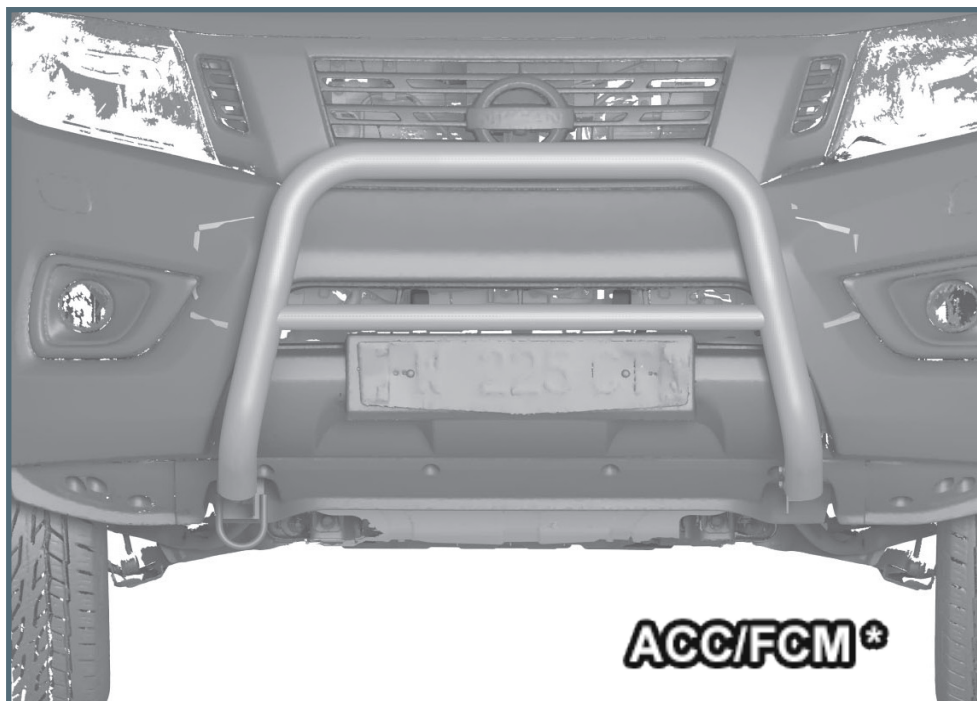

\*Compatible with Automatic Cruise Control /Forward Collision Mitigation  
Kompatibel mit Abstandsregeltempomat /Auffahrvermeidungs-oder warnsystem  
compatible avec radar de régulation de distance/ freinage autonome d'urgence

Not Compatible with Front camera  
Nicht kompatibel mit Frontkamera  
pas compatible avec caméra frontale



# **ASSEMBLY INSTRUCTION**

**Montageanleitung • Instructions de montage**

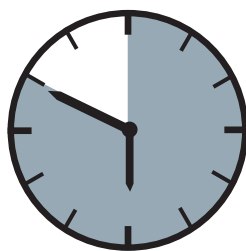

**50 Minuten**

article no.:

17L4313 (S) inox

17L5313 black steel

**Revision 6: 02.11.2021**



[www.antec-online.de](http://www.antec-online.de)

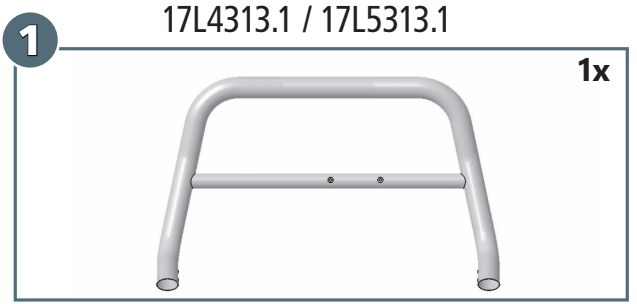
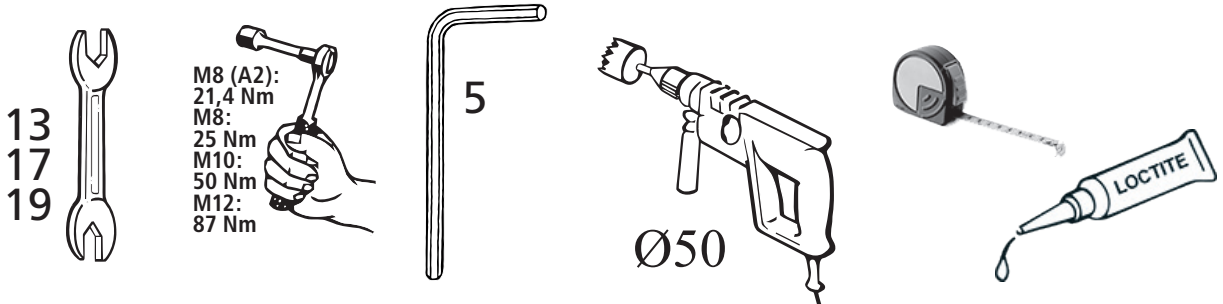

mounting kit: 17L9313

	M8x20; ähnl. ISO 7380 A2	<b>4x</b>
	M8; DIN 934 Zn	<b>2x</b>
	M8x25; DIN 933 A2	<b>2x</b>
	M12x55; DIN 933 Zn	<b>1x</b>
	M10; DIN 934 Zn	<b>2x</b>
	M12; DIN 934 Zn	<b>1x</b>
	Ø 8,4; DIN 125 Zn	<b>2x</b>
	Ø 8,5; DIN 9021 A2	<b>4x</b>
	SW13	<b>2x</b>

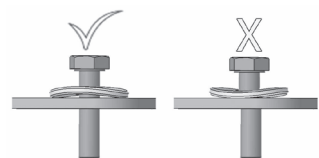
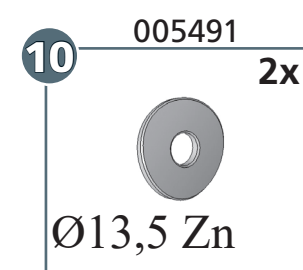
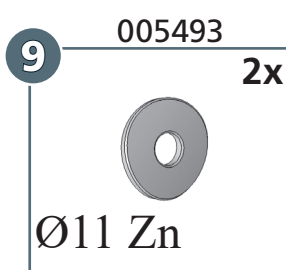
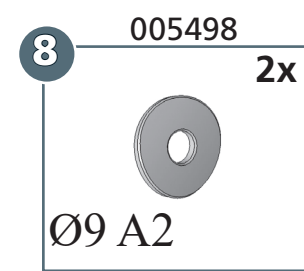
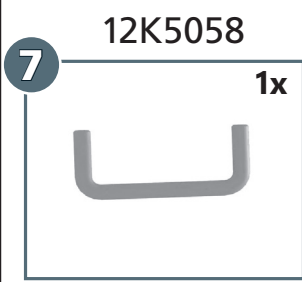
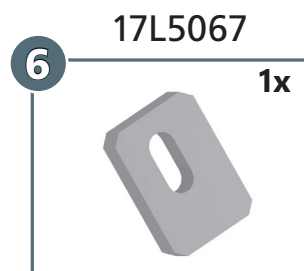
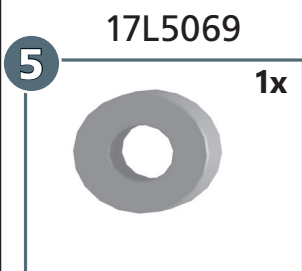
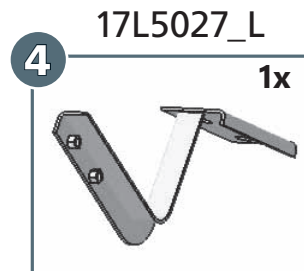
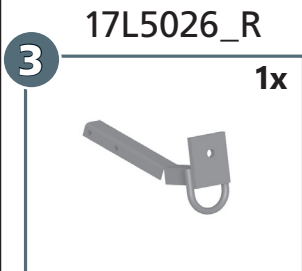
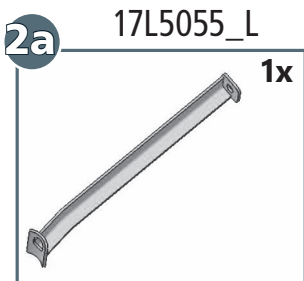
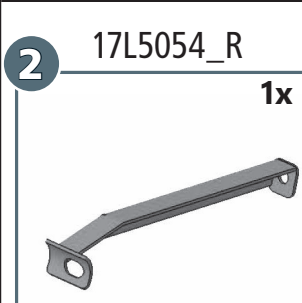

article no.:  
17L4313 (S) inox  
17L5313 black steel

Revision 6: 02.11.2021



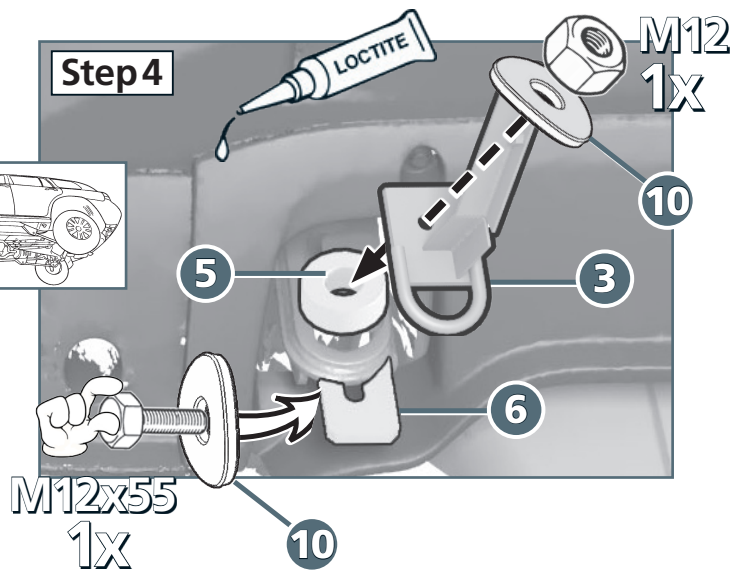
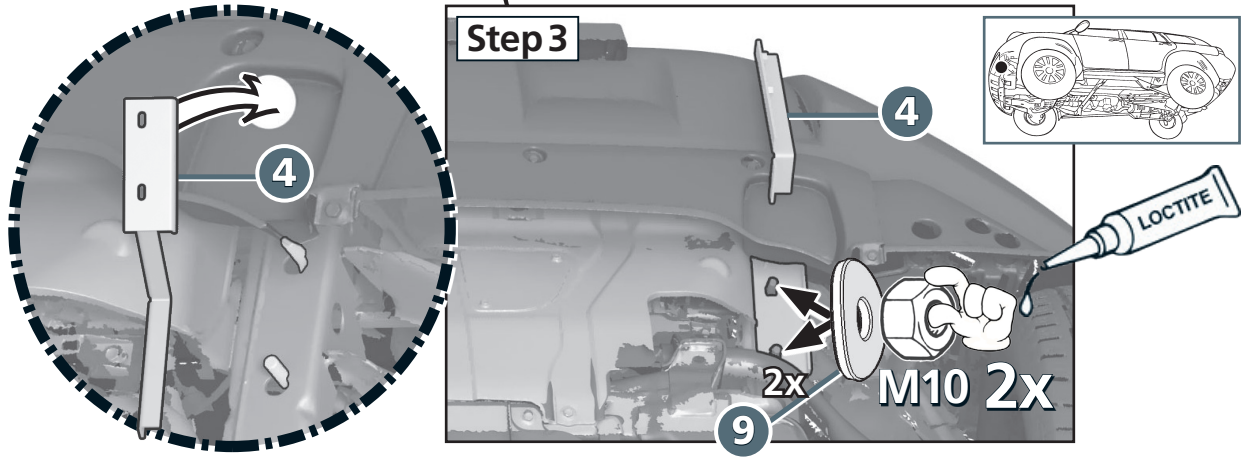
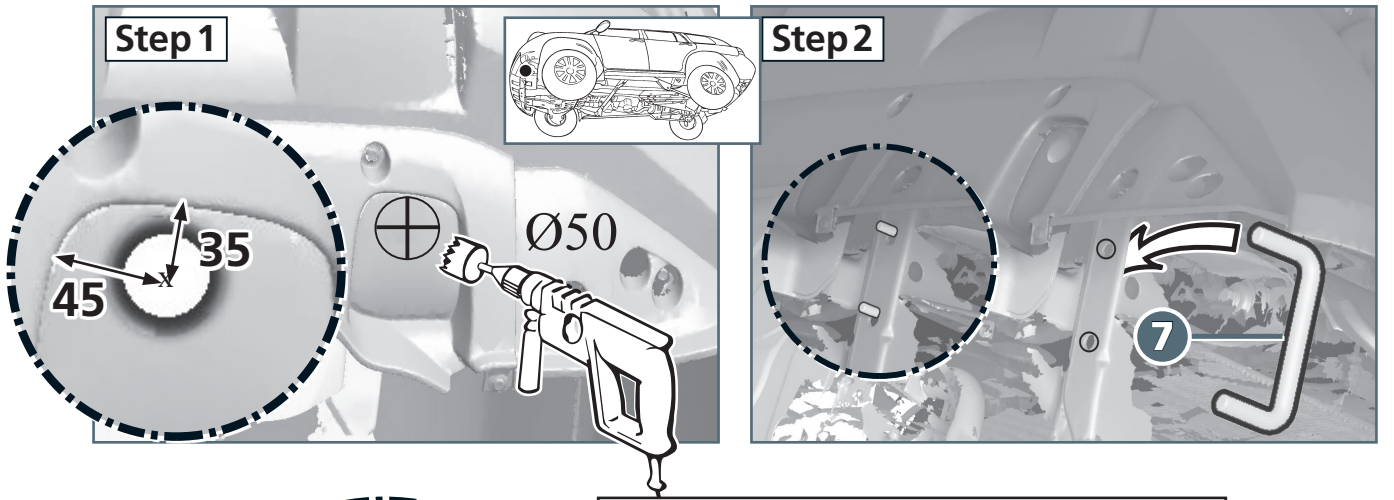



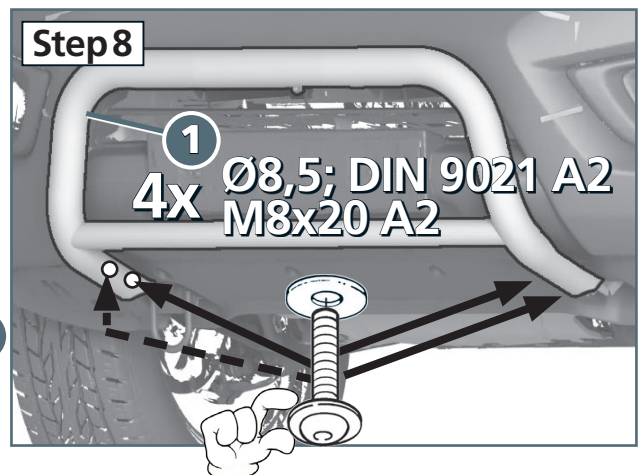
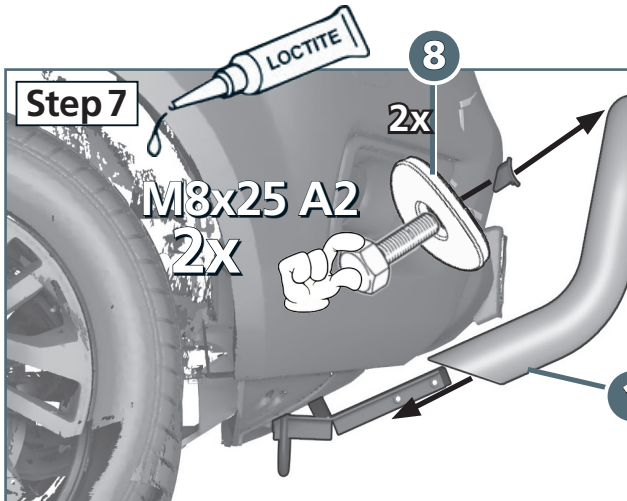
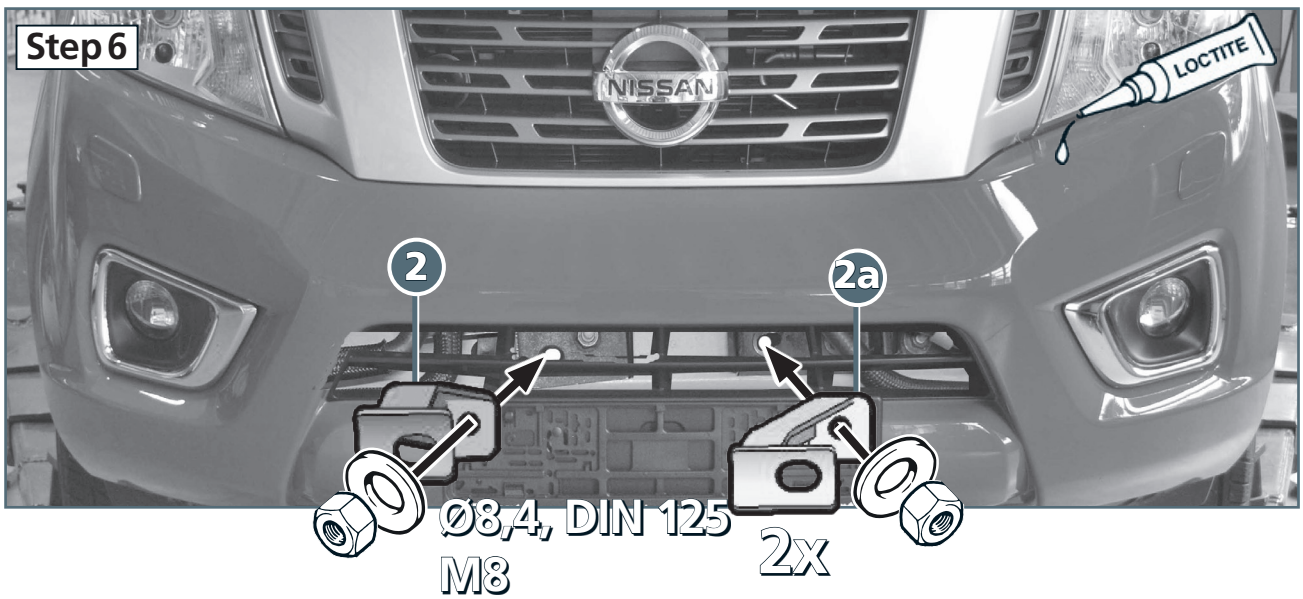
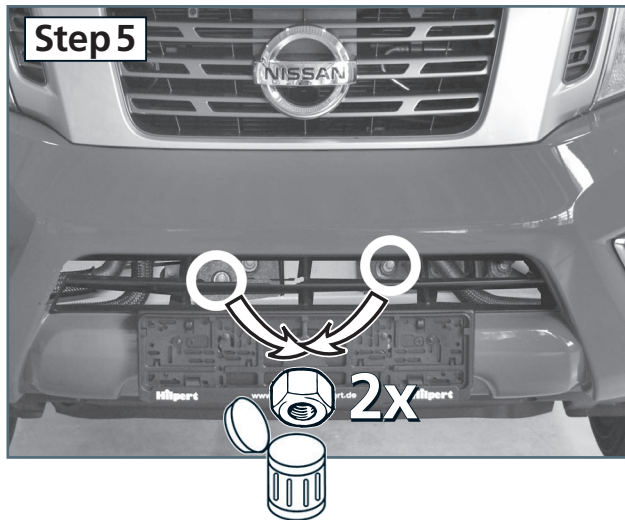

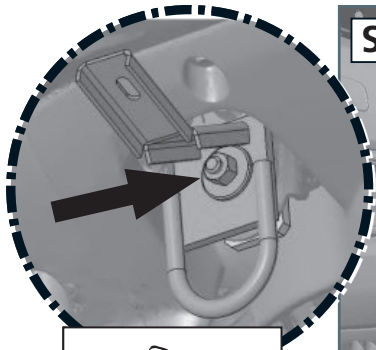

Step 9

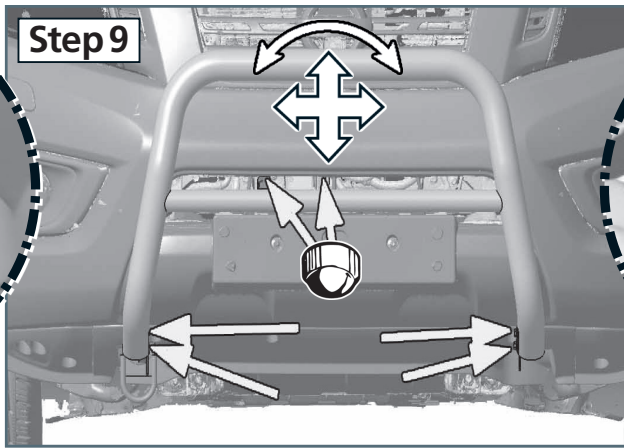

M8 (A2):  
21,4 Nm  
M8:  
25 Nm  
M10:  
50 Nm  
M12:  
87 Nm



Step 10

