



STEELER

SOKÓŁKA

www.steeler.pl

MITSUBISHI L200 2010r.



FITTING INSTRUCTION

(Front bullbar)

L200N-R0085

L200N-R0085-03

L200N-R0085-04



Bullbar with homologation „e”

Specification of full assembly:

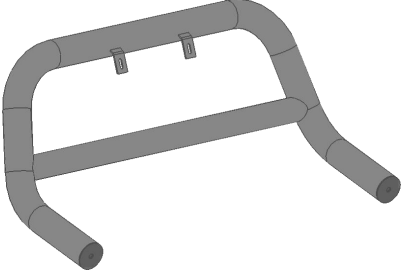
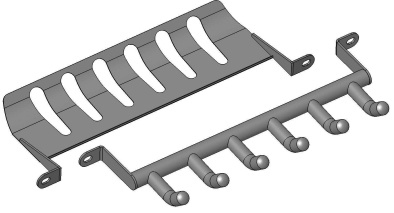
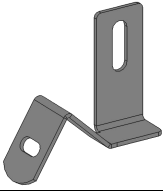
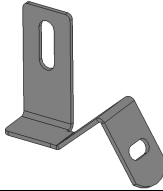
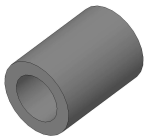
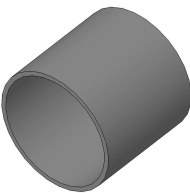
<p>1. Bullbar (1 pc.)</p> 	<p>2. Lower metal plate/Grate(1 pc.)</p> 
<p>3. Lower left attachment (1 pc.)</p> 	<p>4. Lower right attachment (1 pc.)</p> 
<p>5. Quill I (2 pcs.)</p> 	<p>6. Quill II (2 pcs.)</p> 

Connecting components:

Screws:

M6x50- 2 pcs.
M10x70- 1 pcs. (fine thread)
M10x70- 1 pcs.
M12x35- 2 pcs.

Washers:

Ø6,5- 2 pcs. (large washer)
Ø11- 3 pcs. (large washer)
Ø13- 2 pcs. (large washer)

Nuts:

M10- 1 pcs.

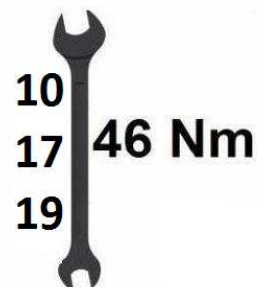

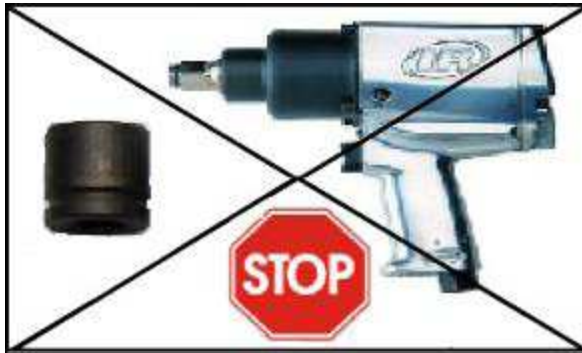

Fitting time:



1 h

ATTENTION: *Foil remove after fitting !*

Bullbar fitting (standard):

L200N-R0085-03

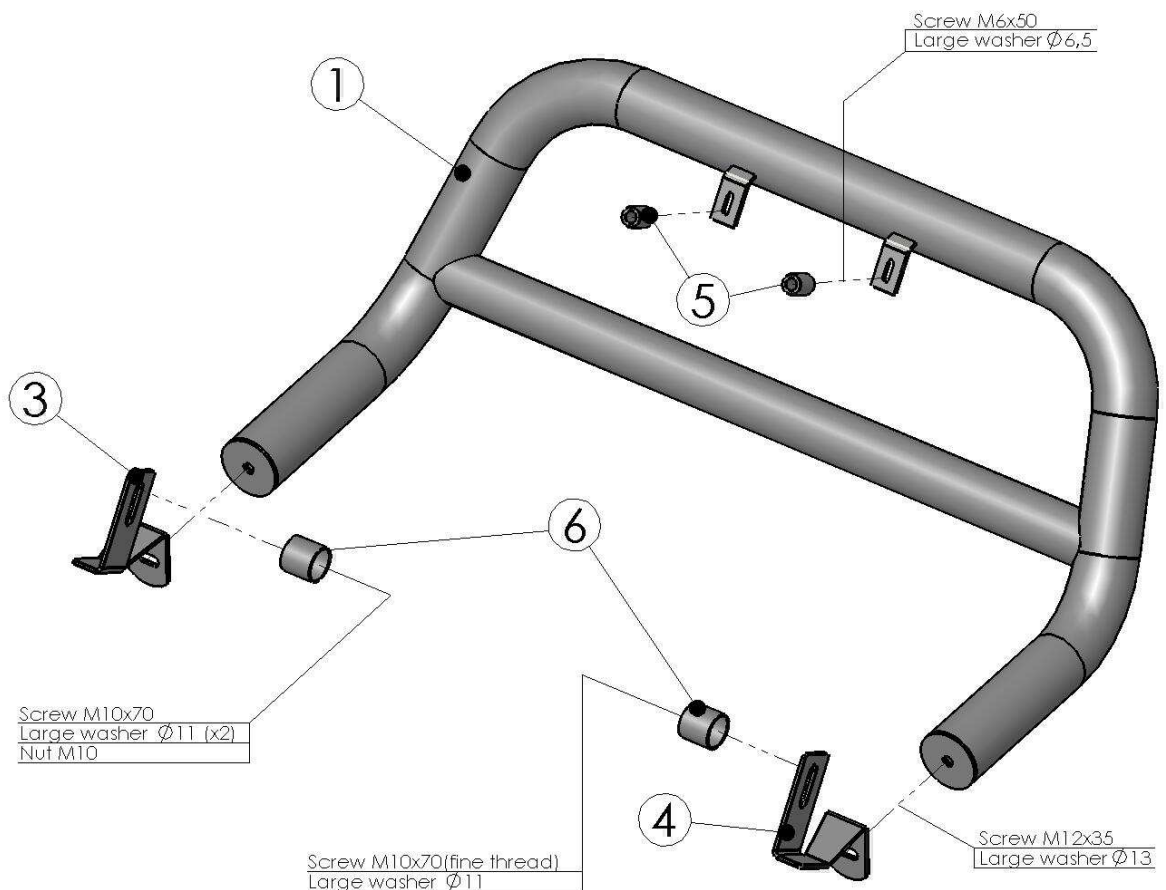

10.4kg

Bullbar fitting (lower metal plate):

L200N-R0085-04

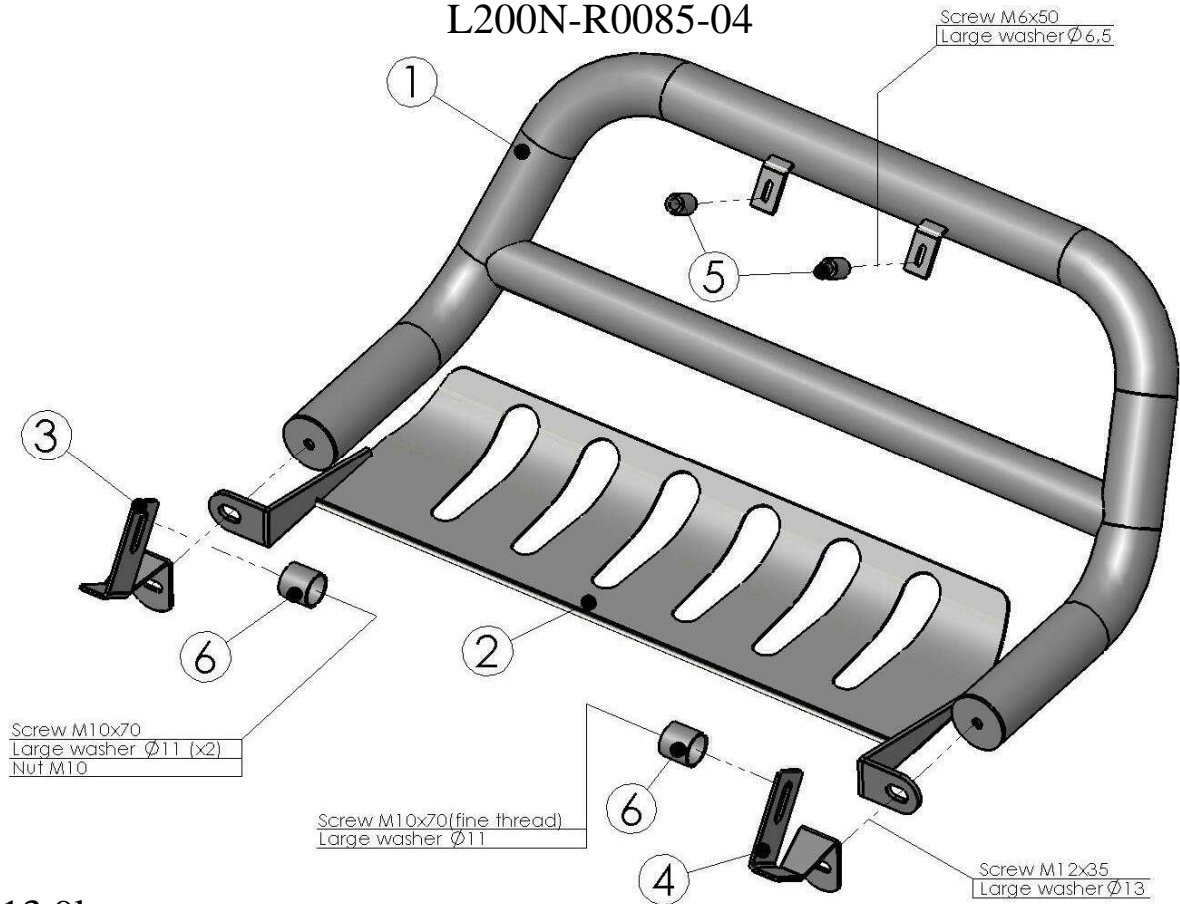

13.9kg

Bullbar fitting (grate):

L200N-R0085

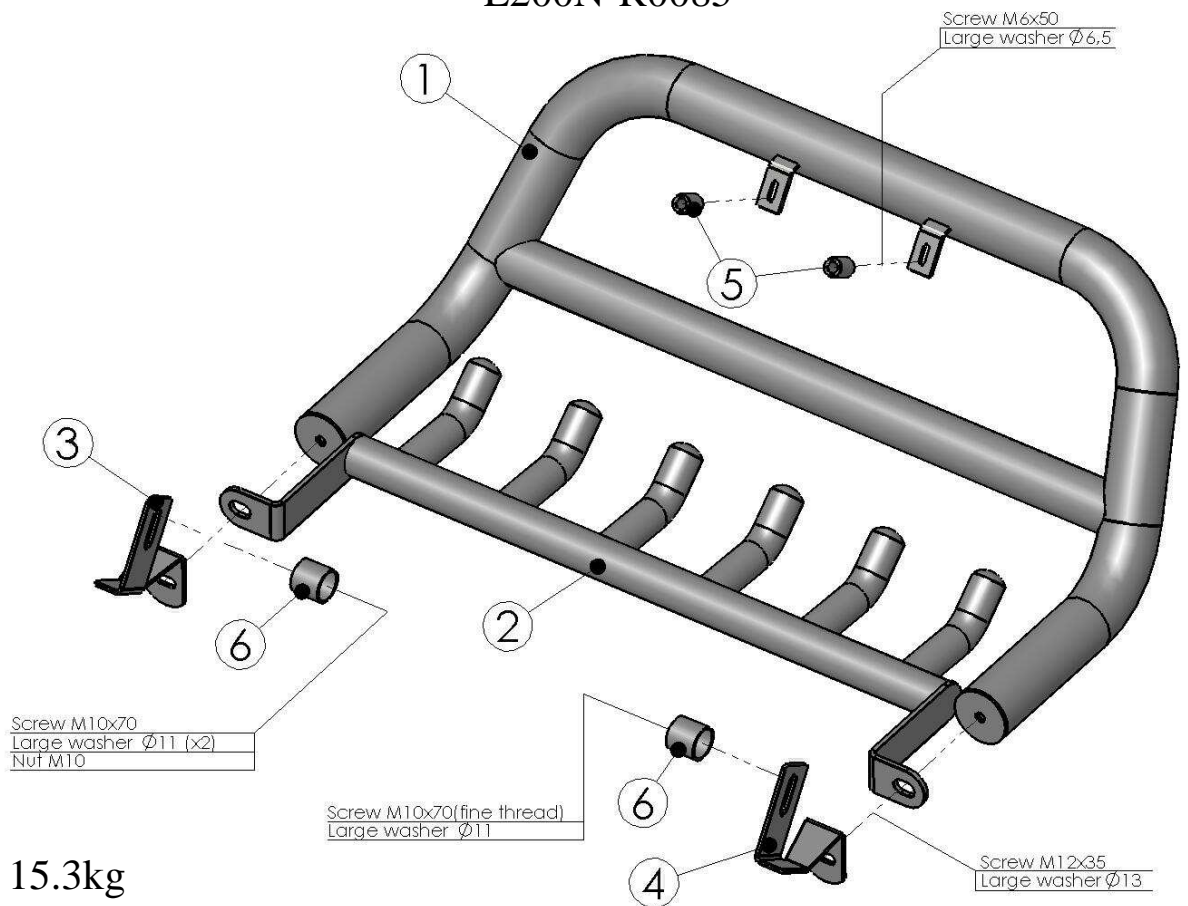

15.3kg

Left, lower attachments:

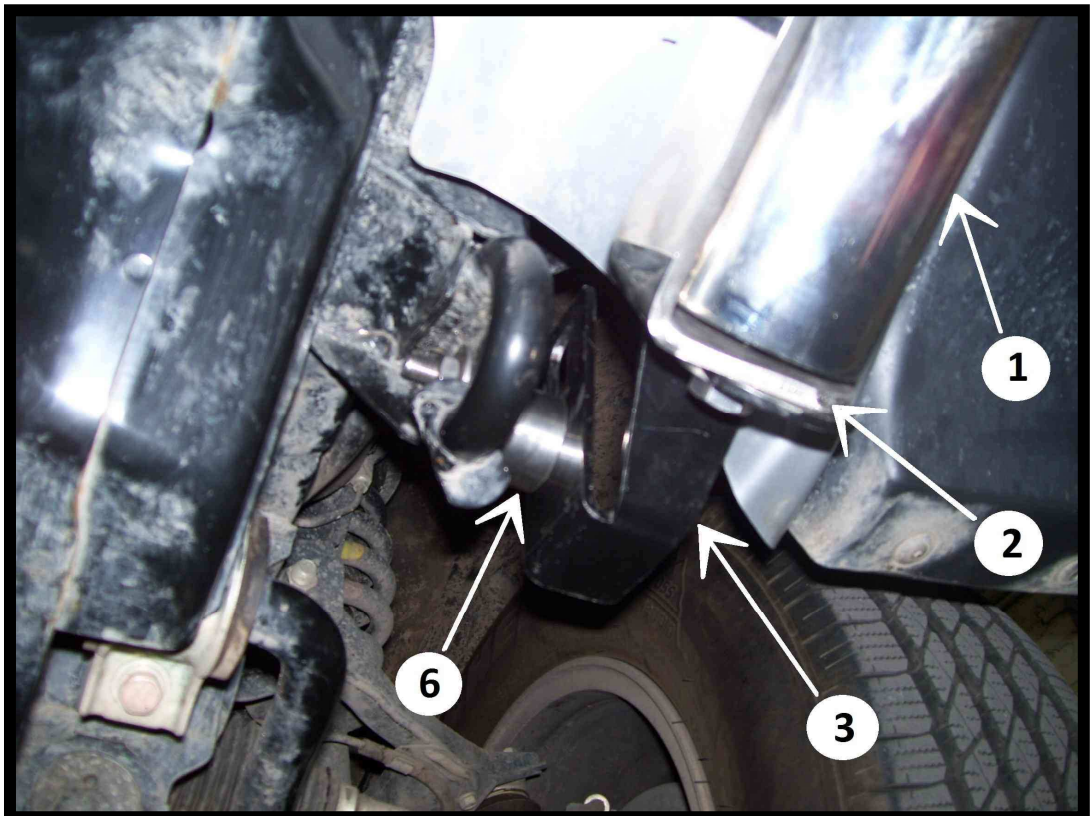
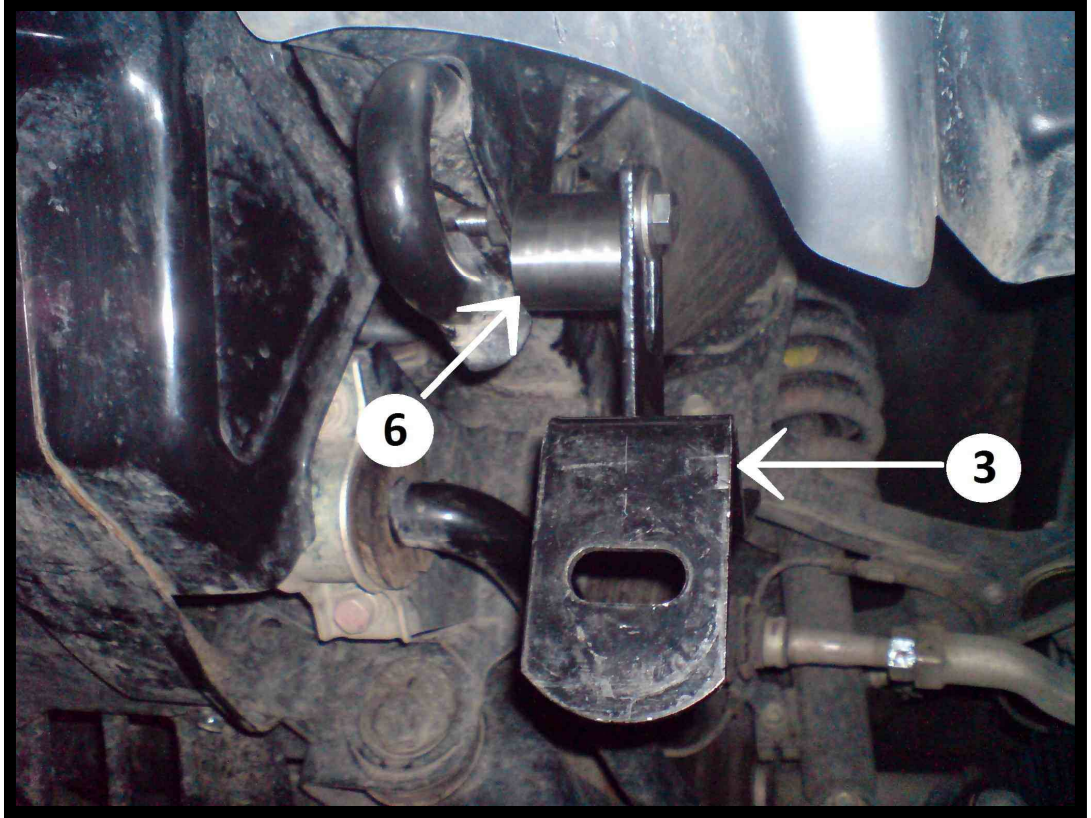
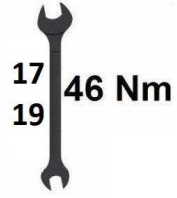

Right, lower attachments:

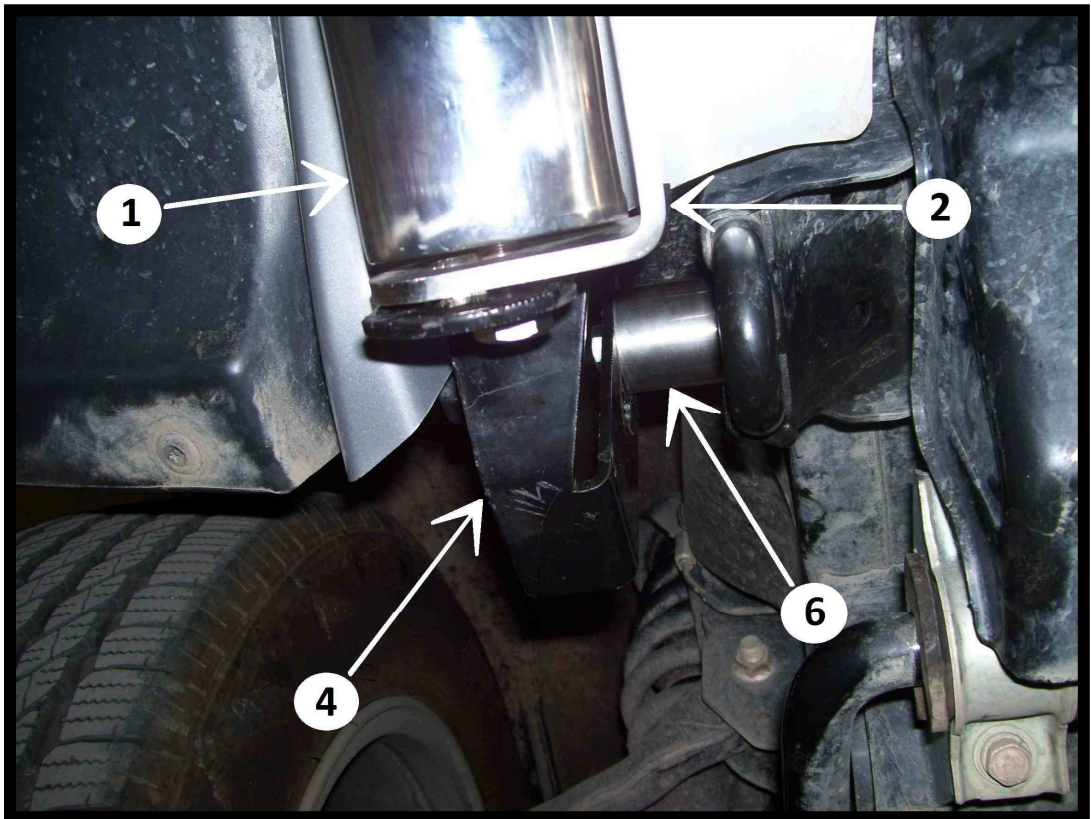
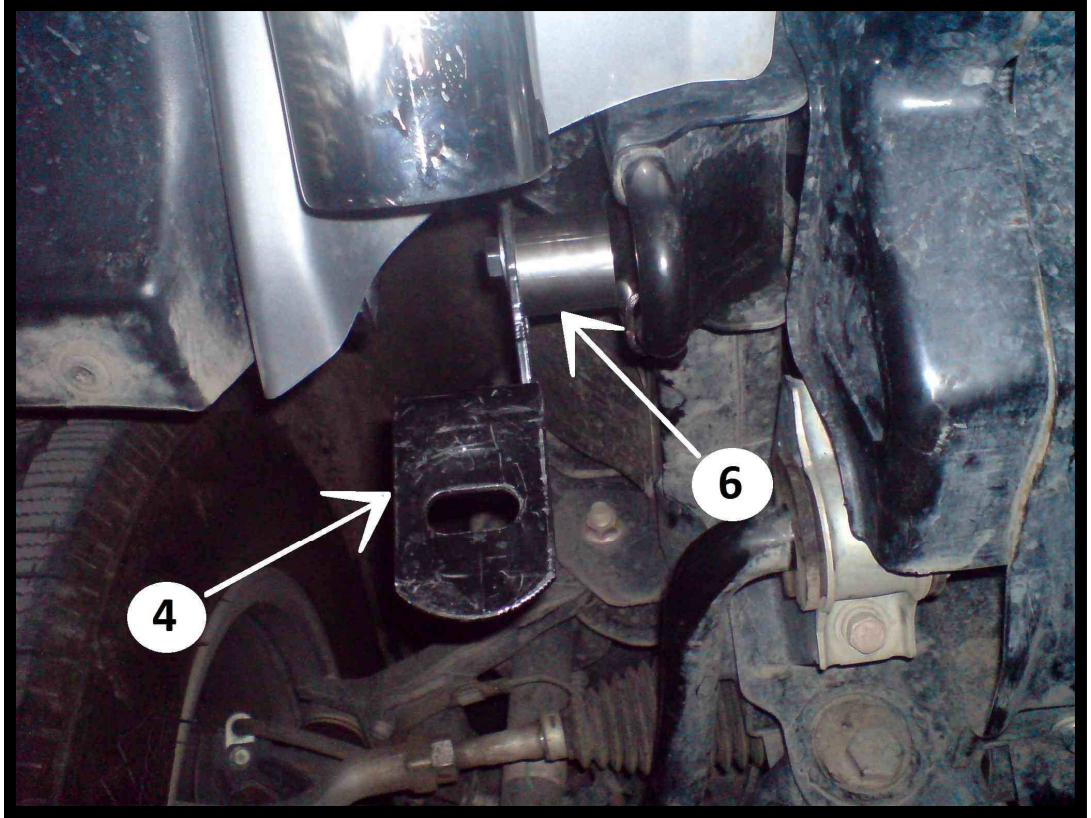

Upper attachments:

