



STEELER

SOKÓŁKA

www.steeler.pl

SEAT ATECA 2016



INSTRUKCJA MONTAŻU

(Orurowania przednie rozłożyste)

FITTING INSTRUCTION

(Extensive front bullbar)

Инструкция монтажа

(кенгурин широкий)

MONTAGEANLEITUNG

(Frontschutzbügel)

ATECA-L1660-05

ATECA-L1660-07

ATECA-L1660-08









Orurowania z homologacją „e”

Bullbar with homologation „e”

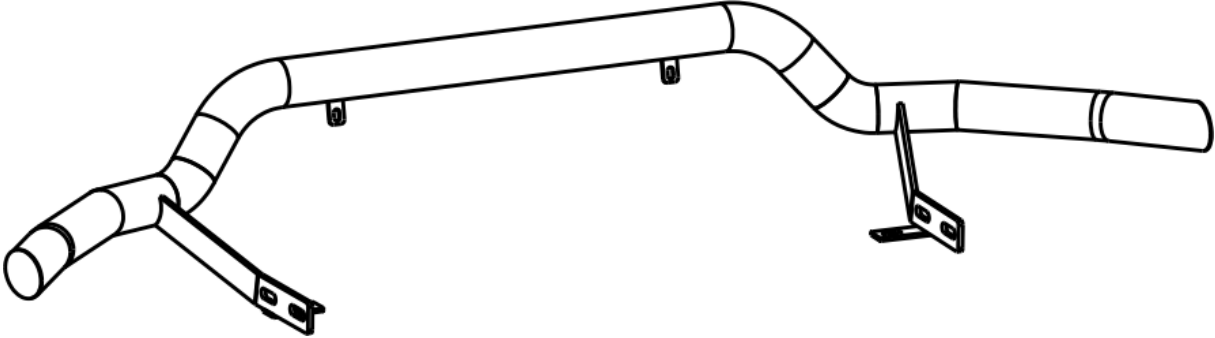
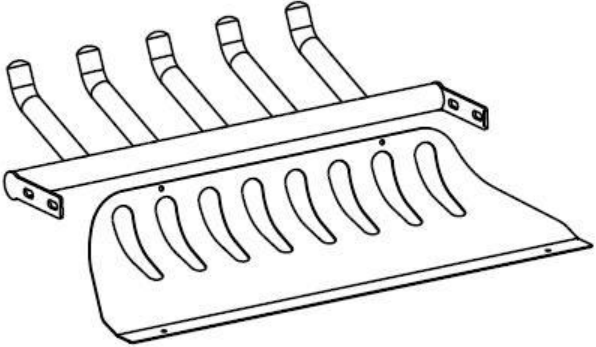
Тюнинг с омологацией „e”

Frontschutzbügel mit „e“- Prüfzeichen

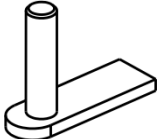
Wykaz elementów orurowania:
Specification of full assembly:
Список элементов тюнинга:
Liste der Elemente:

<p>1. Rura przednia (szt. 1) / Bullbar (1 pc.) / Передняя дуга (шт.1) / Frontbügel (st.1)</p>	
<p>2. Blacha dolna / grill (szt. 1) Lower metal plate / Grate (1 pc.) Защита картера / гриль (шт.1) Unterfahrerschutz (st.1)</p>	
<p>3. Zamocowanie dolne I (szt. 2) Lower attachment I (2 pcs.) Крепление нижнее I (шт.2) Montage unten I (st.2)</p>	
<p>4. Zamocowanie dolne II (szt. 2) Lower attachment II (2 pcs.) Крепление нижнее II (шт.2) Montage unten II (st.2)</p>	
<p>5. Zamocowanie dolne lewe III (szt. 1) Lower left attachment III (1 pc.) Крепление нижнее левое III (шт.1) Montage unten links III (st.1)</p>	
<p>6. Zamocowanie dolne prawe III (szt. 1) Lower right attachment III (1 pc.) Крепление нижнее правое III (шт.1) Montage unten rechts III (st.1)</p>	
<p>7. Szpilka M12x45 (szt. 2) Skewer M12x45 (2 pcs.) Шпилька M12x45 (шт.2) Stecknadel M12x45 (st.2)</p>	
<p>8. Podkładka (szt. 2) Washer (2 pcs.) Шайбы (шт. 2) Unterlegscheiben (st. 2)</p>	

Wykaz elementów łącznych:
Connecting components:
Список соединительных элементов:
Die Auflistung der Elemente:

ATECA-L1660-05 / ATECA-L1660-07

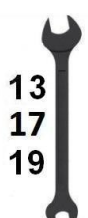
Śruby (szt.) Screws (pcs.) Болты (шт.) Schrauben (st.)	M8x30 – (2) M10x30 – (6) M12x45 – (2) (szpilka – skewer)	Nakrętki (szt.) Nuts (pcs.) Гайки (шт.) Muttern (st.)	M8 – (2) M10 – (6) M12 – (2)
Podkładki (szt.) Washers (pcs.) Шайбы (шт.) Unterlegscheiben(st.)	Ø 8 – (4) – XL Ø 8 – (2) – SPR Ø 10 – (12) – XL Ø 10 – (6) – SPR Ø 12 – (2) – XL Ø 12 – (2) – SPR		

ATECA-L1660-08

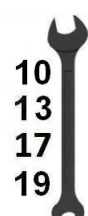
Śruby (szt.) Screws (pcs.) Болты (шт.) Schrauben (st.)	M6x20 – (4) M8x30 – (2) M10x30 – (6) M12x45 – (2) (szpilka – skewer)	Nakrętki (szt.) Nuts (pcs.) Гайки (шт.) Muttern (st.)	M6 – (4) M8 – (2) M10 – (6) M12 – (2)
Podkładki (szt.) Washers (pcs.) Шайбы (шт.) Unterlegscheiben(st.)	Ø 6 – (4) – XL Ø 6 – (4) – SPR Ø 8 – (4) – XL Ø 8 – (2) – SPR Ø 10 – (12) – XL Ø 10 – (6) – SPR Ø 12 – (2) – XL Ø 12 – (2) – SPR		

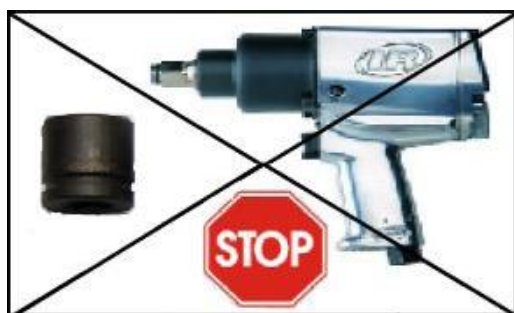

1 h

Czas montażu
Fitting time
Время монтажа
Montagezeit

M6 - 7 Nm	M8 - 17 Nm	M10 - 33 Nm	M12 - 57 Nm
-----------	------------	-------------	-------------

UWAGA: Folię usunąć dopiero po montażu!

ATTENTION: Foil remove after fitting!

ВНИМАНИЕ: Целлофан снять только после завершения монтажа!

HINWEIS: Die Folie soll erst nach der Montage entfernt werden!

Montaż orurowania / Bullbar fitting / Монтаж защиты / Montage der Schwellerrohre
ATECA-L1660-05

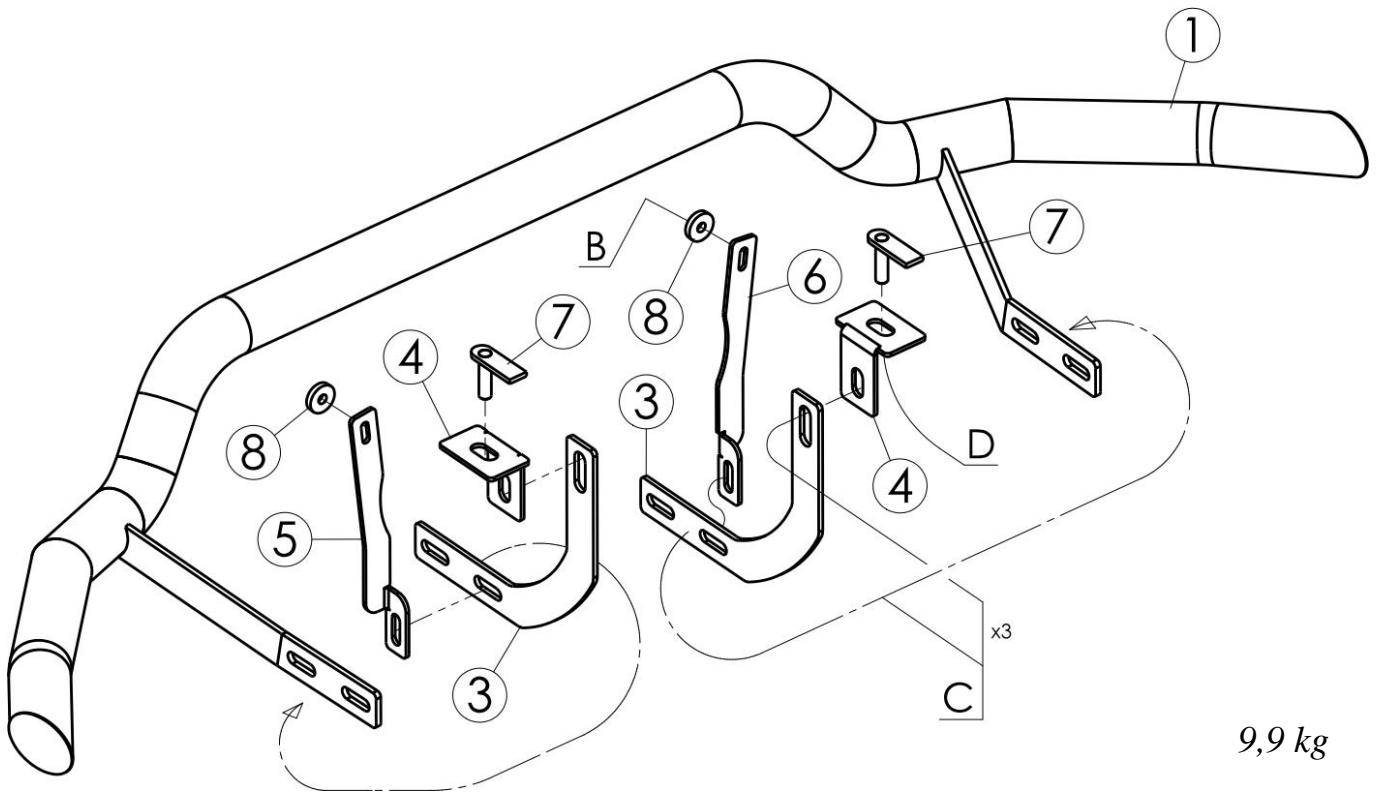

Montaż orurowania / Bullbar fitting / Монтаж защиты / Montage der Schwellerrohre
ATECA-L1660-07

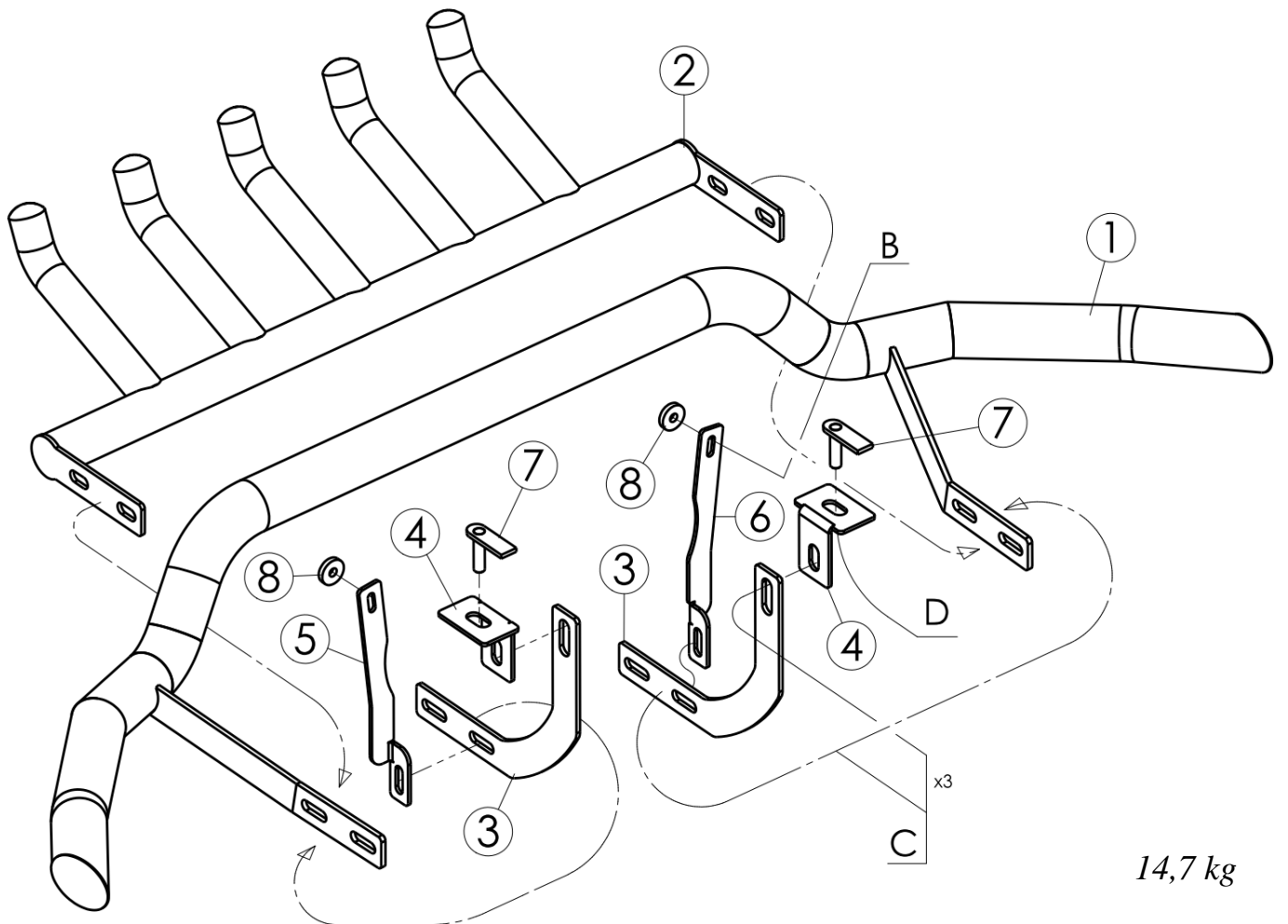

Montaż orurowania / Bullbar fitting / Монтаж защиты / Montage der Schwellerrohre
ATECA-L1660-08

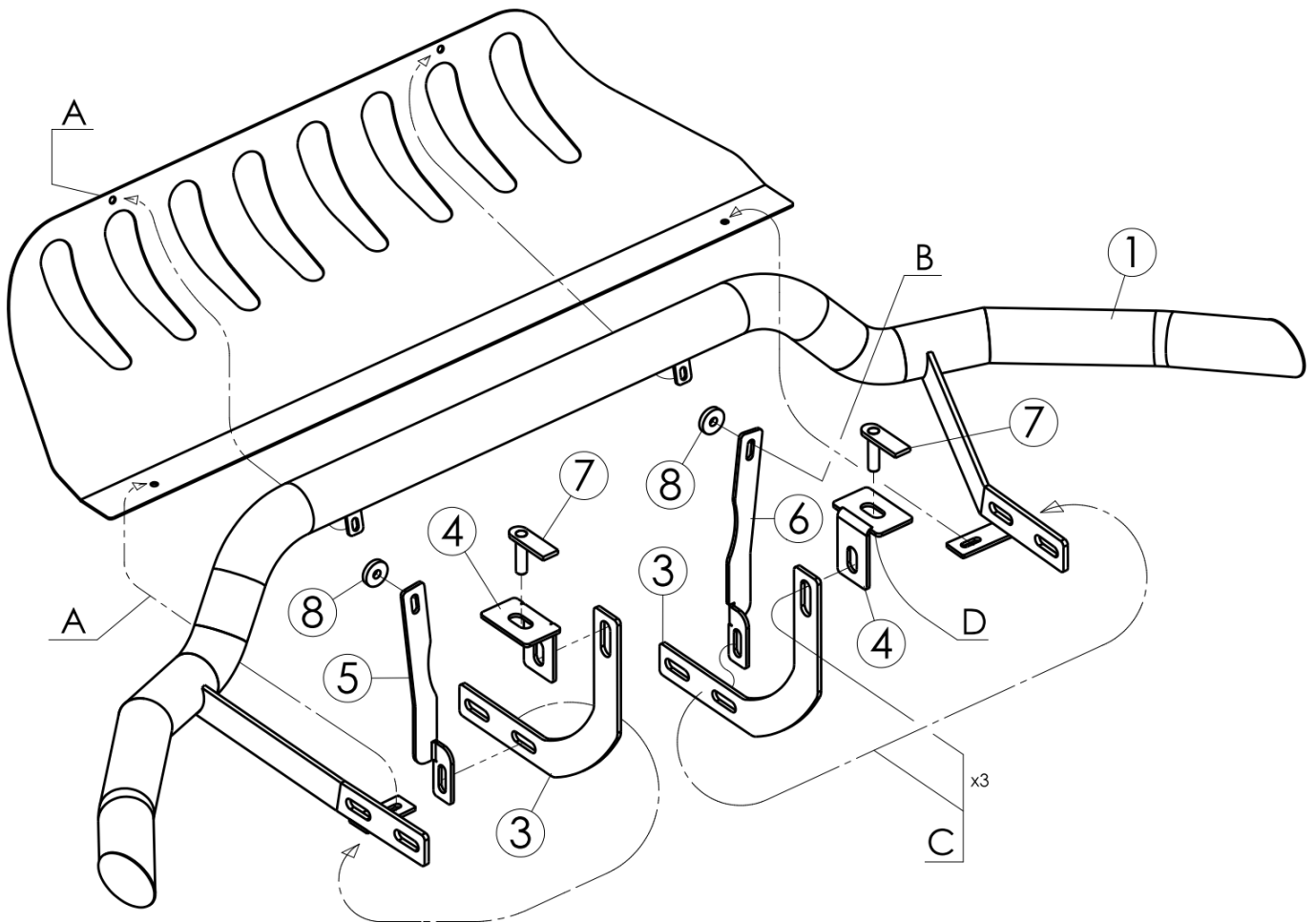

14,3 kg

	Śruby (szt.) Screws (pcs.) Болты (шт.) Schrauben (st.)	Podkładki (szt.) Washers (pcs.) Шайбы (шт.) Unterlegscheiben (st.)	Nakrętki (szt.) Nuts (pcs.) Гайки (шт.) Muttern (st.)
A	<i>M6x20</i>	<i>Ø6-XL, Ø6-SPR</i>	<i>M6</i>
B	<i>M8x30</i>	<i>Ø8-XL(x2), Ø8-SPR</i>	<i>M8</i>
C	<i>M10x30</i>	<i>Ø10-XL(x2), Ø10-SPR</i>	<i>M10</i>
D	<i>M12x45</i>	<i>Ø12-XL, Ø12-SPR</i>	<i>M12</i>

D – szpilka / skewer / шпилька / Stecknadel

*Lewa część orurowania / Left attachments / Левая часть защиты
/Linke Seite des Frontschutzbügels*

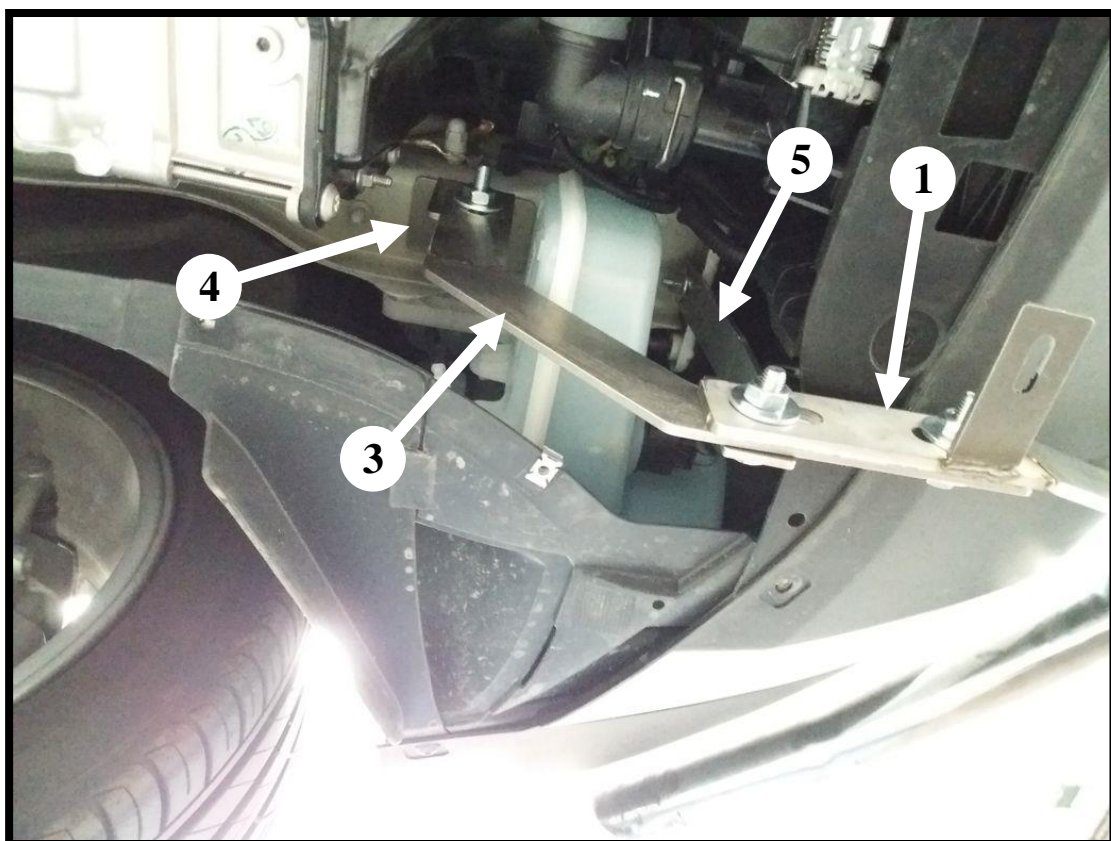
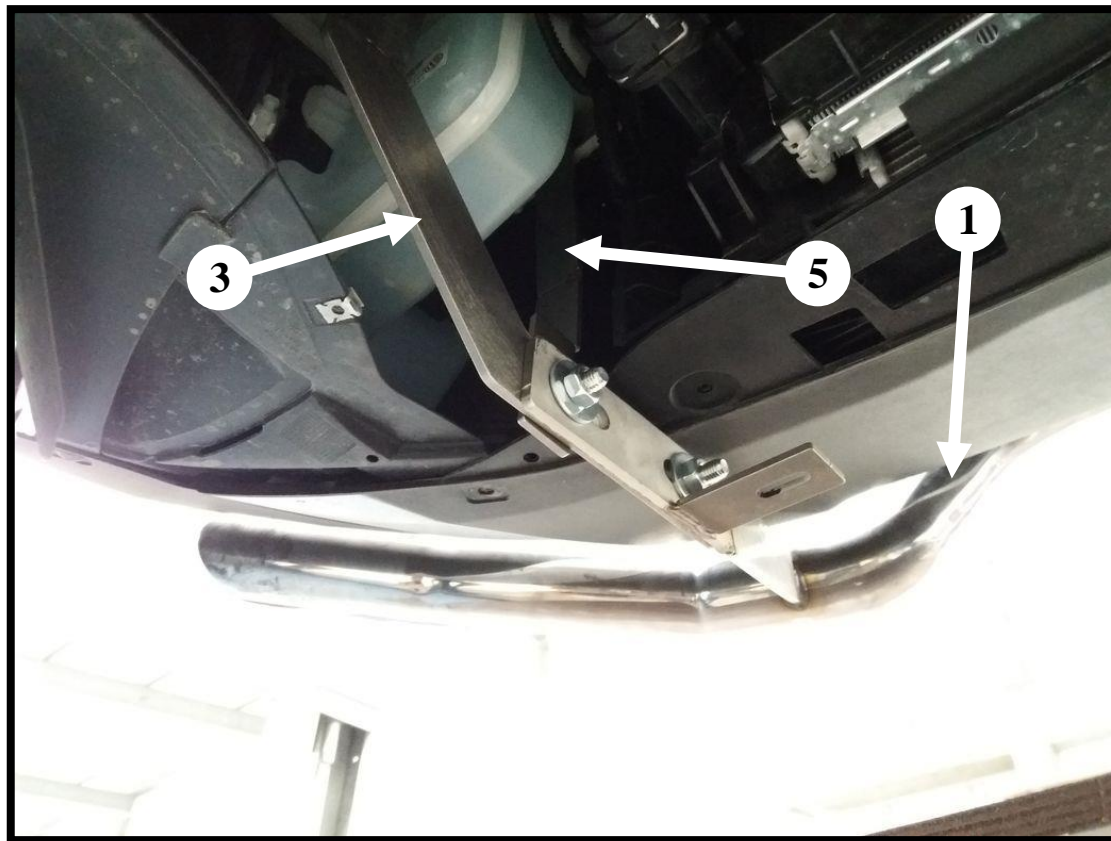
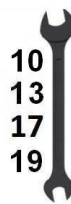

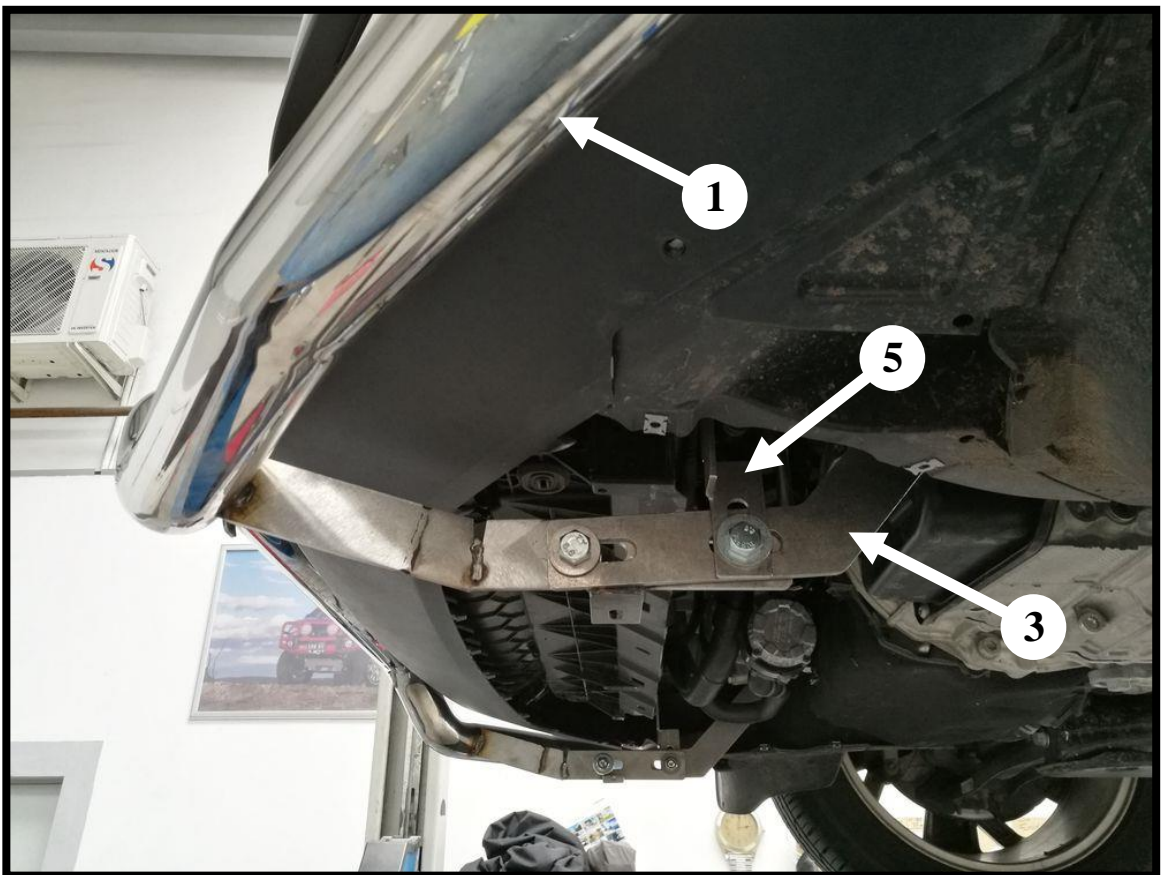
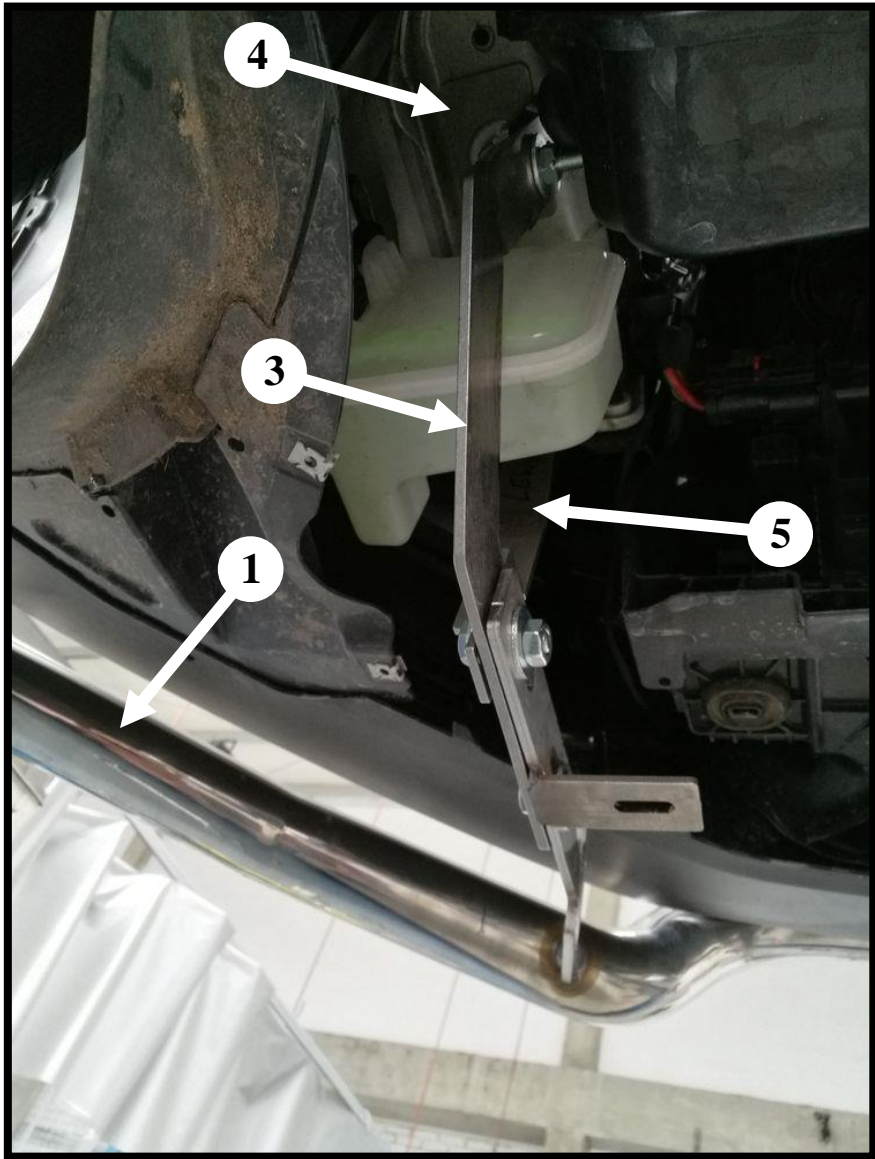

*Prawa część orurowania / Right attachments / Правая часть
защиты / Rechte Seite des Frontschutzbügels*



